

Virtual Power Plants on the basis of managed Plug-in Vehicles and Heat Pumps

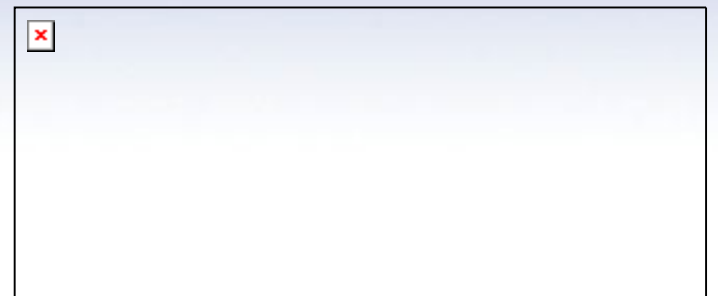

Thomas Karl Reis, CEO
microsolar.at gmbh
t.reis@microsolar.at

01-03-2009

Renewable Energy and their fluctuating Production

- Classical approach with balanced energy
 - Centralized
 - Hierarchy structured Grid
- Approach with managed plug-in loads
 - Decentralized
 - Fluctuating, variable production
 - Ambitious directive to increase production
 - Costly to restructuring the grid vs
 - Active or Smart Grid

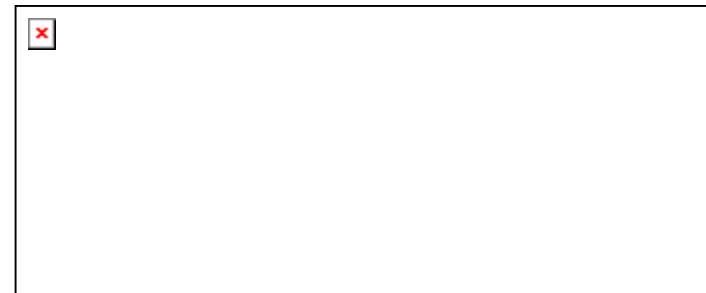

Case I

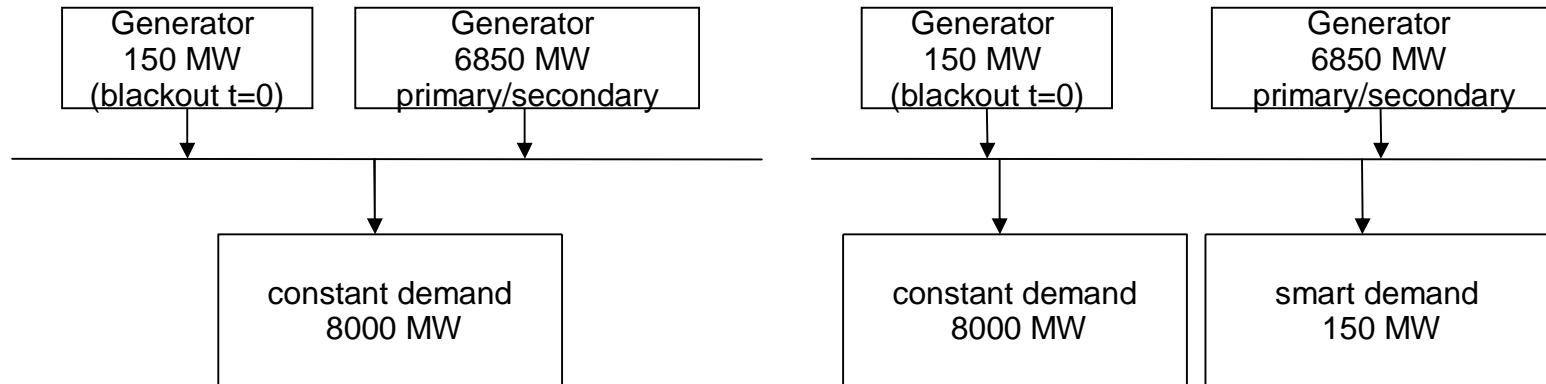

- With Frequency Controller GridWise GridFriendly virtual Power Plants with a Last Shifting Capacity of 150 MW Thermostats coupled with frequency for Peak shaving and power balancing. Unfortunately not stable

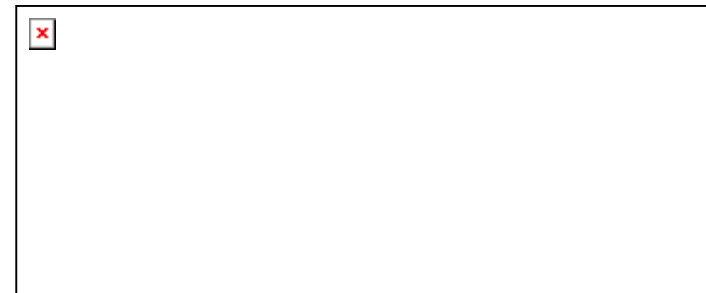

Case II

- Centralized Powermanagement

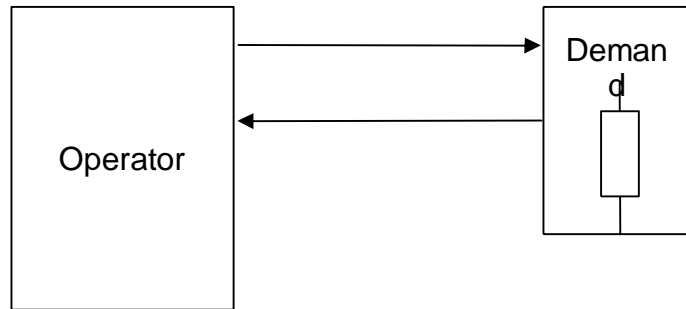

- Centralized Powermanagement with Agents (IRON)

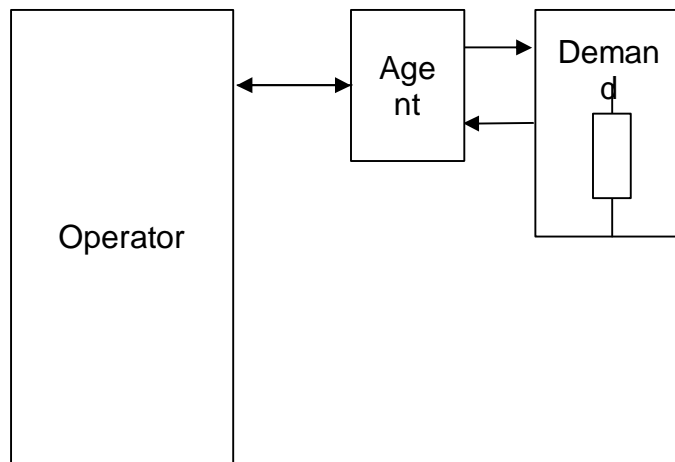

Source: IRON, TU-Vienna

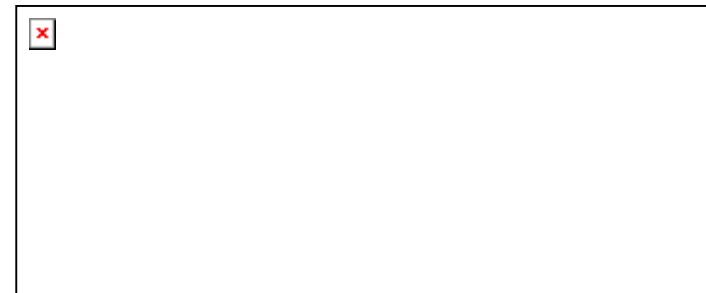

Case III

- Multifunctional PV battery systems for industrial applications
- Benefits: Profit from Day-Ahead-Trading, power quality and reliability. Multi PV battery systems can improve power quality, substitute uninterruptible power supply systems, and can offer additional services such as energy management and peak shaving

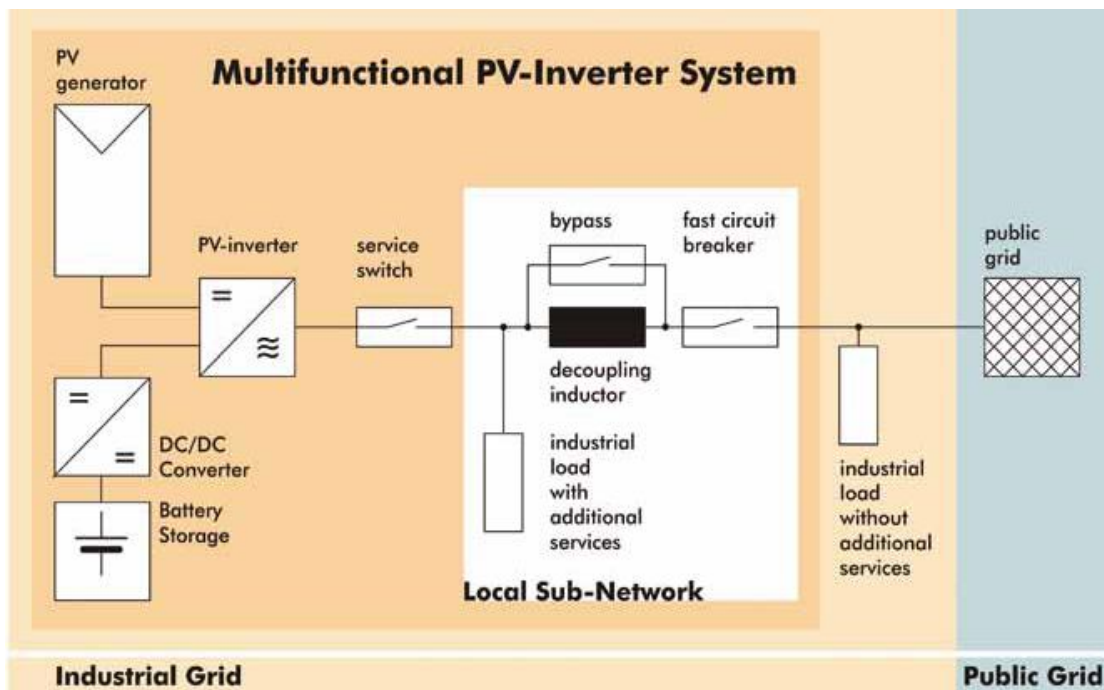

Source: pv-tech.org

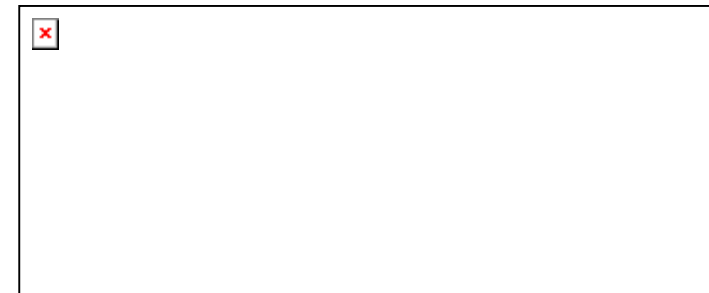

Conclusion and recommendation

- Legislative

- Developments

Vehicle2Grid, Refridgerator2Grid, etc.

- Standards

- National Level

Substitution for renewable Energy and Integration, more money for developing companies

- Global Level

USA and China is investing Billions into these technologies:
BYD, CISCO, MICROSOFT, SAP

Contact: t.reis@microsolar.at or
www.microsolar.at

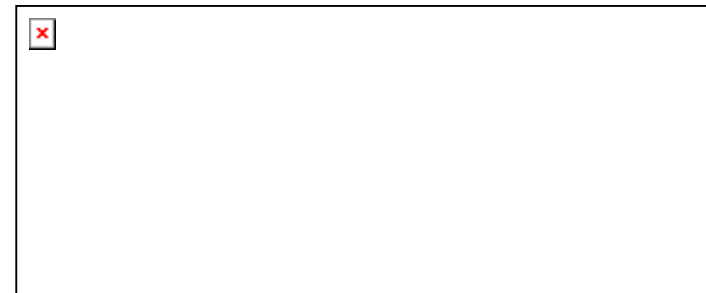

microsolar.at profile

- Developments
Refridgerator2Grid, CCS etc.
- Renewable Energy
Specialist for PV Plants: 3kWp – 2 MWp
- Contact: microsolar.at gmbh, 2512 Tribuswinkel,
Feldgasse 48-50

Contact: t.reis@microsolar.at or
www.microsolar.at

